

13000X778 series

High performance pushbutton switches - threaded bushing Ø 11,9 (15/32)

Distinctive features

UG1006-A

□ Agency approvals



CECC 96401-001

This range of professional switches is suitable for use in military and other high specification environments.



□ Contacts

Highly reliable contacts suitable for low level applications (10mA 50mV, 10µA 5VDC min.) or power applications (2A 250VAC, 4A 125VAC, 4A 30VDC max.)

□ Double shell case

For high mechanical strength and high electrical insulation.



□ Compact size

The small rear end of the switch allows space savings behind the panel.

□ Finish

Matt black finish on body, bushing, plunger and hardware.

□ Full sealing

Panel sealed to IP 67, these switches are frontal sealed by three O-rings and have full rear end sealing.

13000X778 series

High performance pushbutton switches - threaded bushing \varnothing 11,9 (15/32)

Specifications

ELECTRICAL SPECIFICATIONS

- Max. current/voltage rating with resistive load : 2A 250VAC - 4A 125VAC - 4A 28VDC
- Minimum load : 10mA 50mV, 10 μ A 5VDC
When used above 300mA 28VDC, the gold plating is removed on contact areas and is considered only as a protection against oxidation during storage.
- Initial contact resistance : 10 m Ω max.
- Insulation resistance : 1.000 M Ω min. at 500VDC
- Dielectric strength :
1.000 Vrms 50 Hz min. between terminals
2.000 Vrms 50 Hz min. between poles
2.000 Vrms 50 Hz min. between terminals and frame
- Contact bounce : 2 ms max.
- Electrical life :
 - At 2A 250VAC - 4A 28VDC : 10.000 cycles
 - At low level (50mV 10mA) : 150.000 cycles

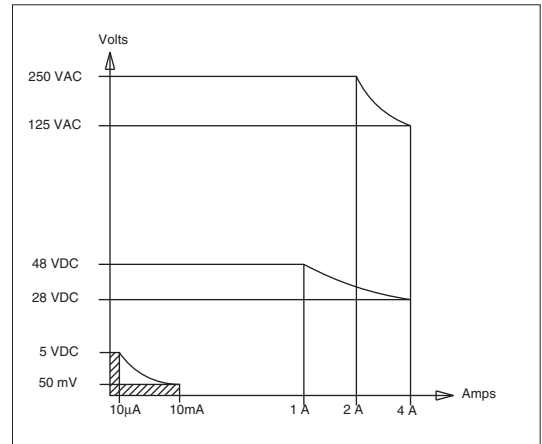

MATERIALS

- Case : diallylphthalate (DAP) with PBT external shell (epoxy sealed)
- Actuator : brass, black chrome plated
- Bushing : brass, black chrome plated
- Contacts : silver inlay - gold plated over nickel barrier

SEALING

- Front panel sealing by three O-rings
- Panel seal withstands 1 bar pressure and remains sealed even when the switch is operated.
- Epoxy sealed terminals
- Splash-proof case

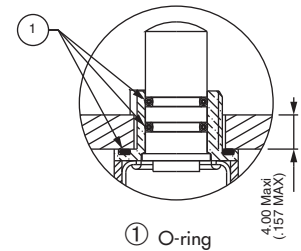

GENERAL SPECIFICATIONS

- Total travel : 2 mm (.078)
- Torque : 1,50 Nm (1.10 Ft.lb) max. applied to nut
- Panel thickness : 5 mm (.196) max.
- Shock test : 50g - 11 ms (IEC 68-2-27)
- Vibrations : 10-500 Hz - 10g (IEC68-2-6)
- Operating temperature : -40 $^{\circ}$ C to +85 $^{\circ}$ C
- Humidity test : 56 days, 93 % R.H., 40 $^{\circ}$ C (IEC 68-2-3)
- Salt spray test : 96 hours (IEC 68-2-11)

APPROVALS

Many models within this range have full CECC approval. To order switches marked CECC, complete appropriate box of ordering format.

13000X778 series

High performance pushbutton switches - threaded bushing Ø 11,9 (15/32)

Overview

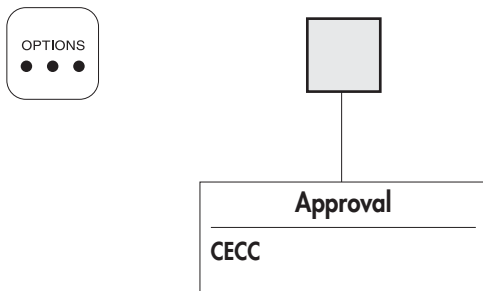
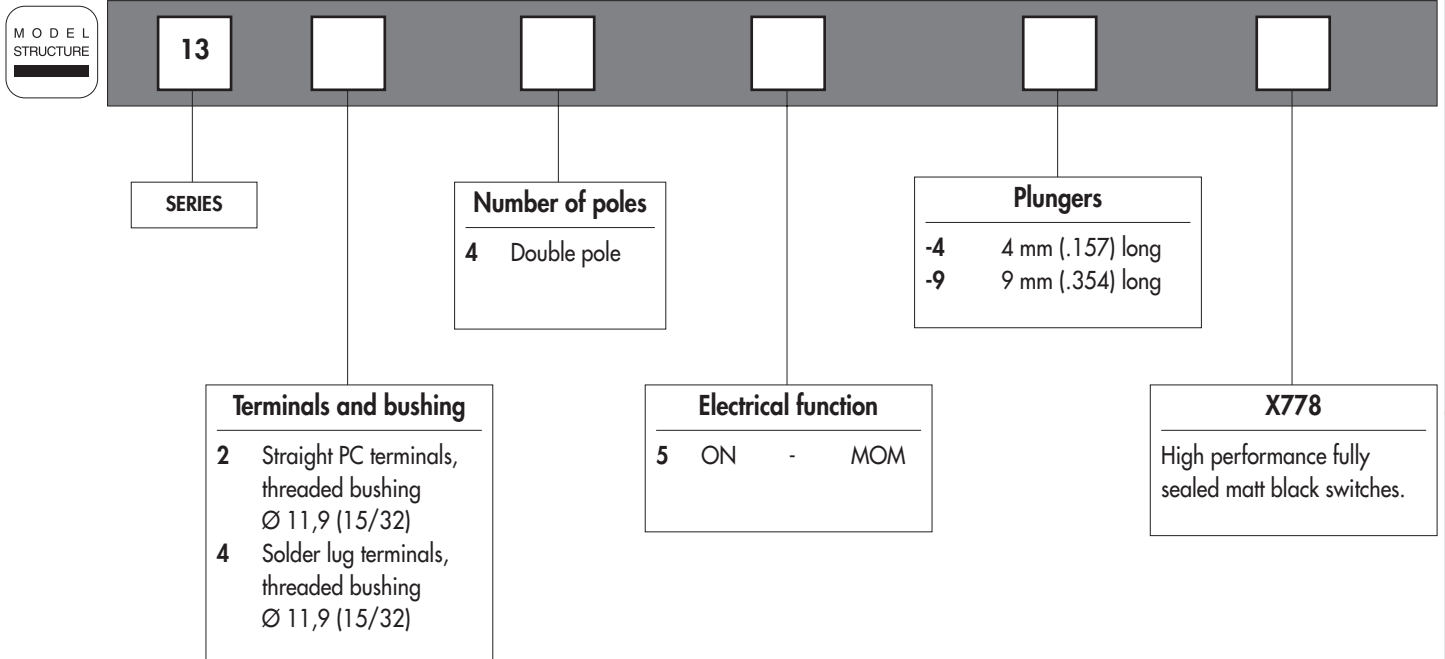

ABOUT THIS SERIES

On the following pages, you will find successively :

- model structure of switches
- options in the same order as in above chart

Dimensions : first dimensions are in mm while inches are shown as bracketted numbers.



Sealing boots can be used to further protect the switches against dust and water. They are presented in section H.



Mounting accessories : standard hardware supplied with all models : 1 hex nut 14 (.551) across flats, part number U41. This nut is presented after model structure of switches.



Security cap available to prevent inadvertent plunger operation. See section I.

Packaging unit : 25 pieces

13000X778 series

High performance pushbutton switches - threaded bushing $\varnothing 11,9$ (15/32)

Fully sealed - matt black

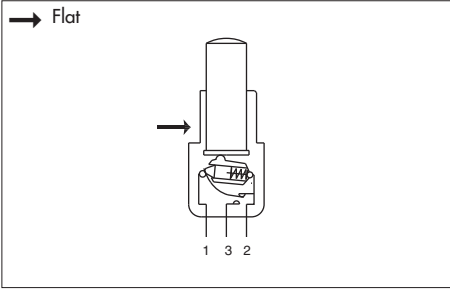

• Quick-break momentary pushbutton switches

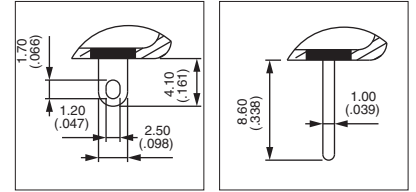

MODEL STRUCTURE

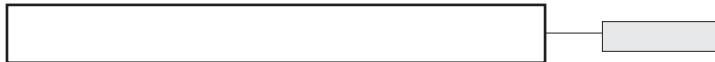

B

Solder lug terminals - double pole - 4 mm (.157) plunger → Flat



13445-4X778

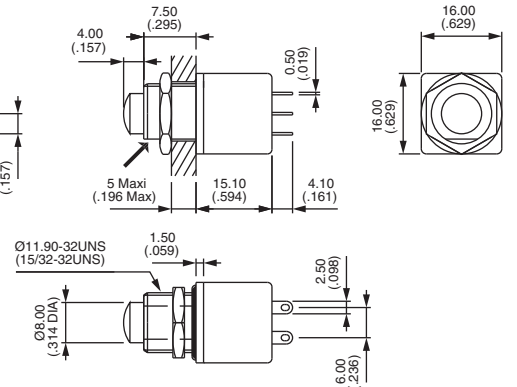
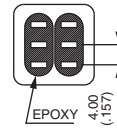
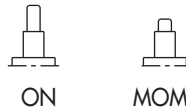

Solder lug terminals - double pole - 9 mm (.354) plunger → Flat



13445-9X778

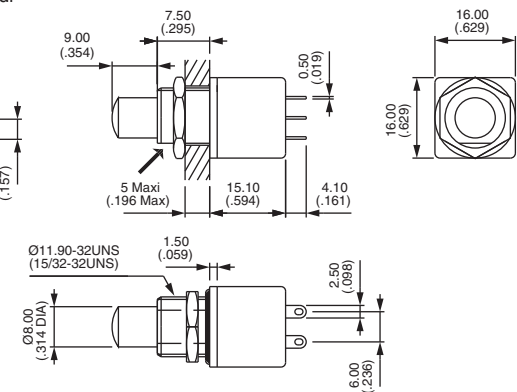
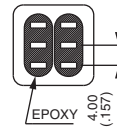
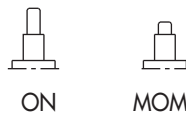

Straight PC terminals - double pole - 4 mm (.157) plunger → Flat



13245-4X778

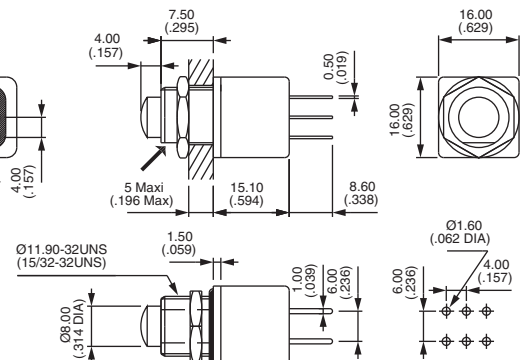
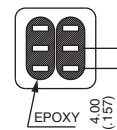

13000X778 series

High performance pushbutton switches - threaded bushing \varnothing 11,9 (15/32)

Fully sealed - matt black

Straight PC terminals - double pole - 9 mm (.354) plunger → Flat



13245-9X778

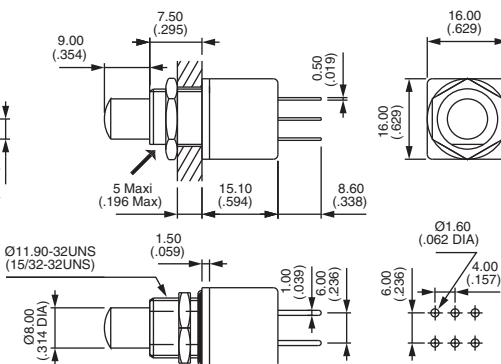
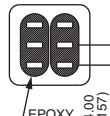

PANEL CUT-OUT

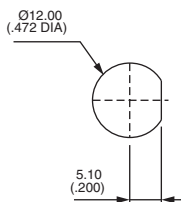

STANDARD HARDWARE

Hex nut

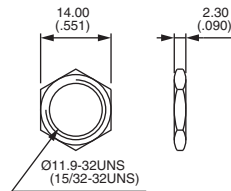

U41 (matt black)

POSITIONS AND CONNECTIONS

FUNCTION	BUTTON POSITION AND CONNECTIONS		TERMINAL IDENTIFICATION
	I	II	
13245 13445	ON A 1-2 B 1-2	MOM A 1-3 B 1-3	→ Flat

AGENCY APPROVAL



CECC CECC 96401-001

Marking : to order switches marked CECC, please complete above box with "CECC".
Blank : no agency approval required.

Mouser Electronics

Authorized Distributor

Click to View Pricing, Inventory, Delivery & Lifecycle Information:

[Apem:](#)

[134459X778](#)